



沈阳蓝光
SHENYANG BLUELIGHT

BLUELIGHT

DRIVE THE FUTURE

HTTP: //WWW.SYLG.CN
2024 . 11

SHENYANG BLUELIGHT NEW GENERATION TECHNOLOGY CO., LTD

Tel: 024-23782971
Address: No. 33, 99A Chuangxin 1st Road,
Hunnan District, Shenyang

SHENYANG BLUELIGHT

DRIVE THE FUTURE

- East China Office Tel: 18602454800
- South China Office Tel: 13709843276
- North China(Shandong) Office Tel: 18642018935
- North China(Harbin)Office Tel: 13936288027

- International Business Department
Tel: +86-24-23780807-717 , +86-24-83786420
E-Mail: zhangruiyan@sylg.cn

SHENYANG BLUELIGHT NEW GENERATION TECHNOLOGY CO., LTD.

COMPANY PROFILE



Elevator Expert

Established in 1989, Shenyang Bluelight was founded by three young master supervisors from Shenyang University of Technology. With more than 30 years' expertise in elevator core products research, develop, production and services, Shenyang Bluelight has earned its fame as the National High-Tech enterprise, member of the China Elevator Association and ISO9001:2015 Quality Management System certified company. Shenyang Bluelight is the only supplier in China who owns the Independent Intellectual Property Rights to provide complete elevator system solutions include but no limited to logic control, drive, traction and monitoring.

Advanced Technology

Over the years, Shenyang Bluelight keeps focusing on innovating technology and has successfully developed: China's first Digital Full Closed-Loop Variable Voltage Variable Frequency Elevator Controller, China's first 32-bit Microprocessor Serial Communication VVVF Elevator Controller, China's first Elevator Safety Remote Monitoring System (Elevator Bodyguard) and many more innovative products with cutting edge technologies. Leading the progress of automatic VF drive technology transforms into digital and intelligent, our BL2000 and BL3000 series elevator controllers and VF drivers are top rated in both technology and market share. The iBL series Intelligent Elevator Controller Systems support connection with smart terminal devices such as a mobile phone to provide various practical and high end functions to guarantee safety. Functions include debugging, fault diagnosis & troubleshooting and mobile remote monitoring, make the "Internet + Elevator" application really come true. Now, many Bluelight's features have become the elevator industrial standards.



Tremendous Competence

Bluelight has Design and Manufacture plants located in Liaoning, Zhejiang and Guangdong provinces. Main sales & services offices are distributed in North East China, North China, East China, South China, South West China, North West China and the network covers most of the country. Every year, Bluelight provides all kinds of elevator services for more than 500 domestic and international customers, including South Korea, Japan, Russia, Saudi Arabia, Turkey, The United Arab Emirates, India, Malaysia and Taiwan.

In the future, Bluelight will continue taking responsibility in elevator industry contribution, focus on the Intelligent Control of Elevator System as our core concept, persevere with our diligence and expertise to provide professional products and service to every customer.





CATALOGUE

1	iBL6 Elevator Integrated Controller	01
2	Car Door Integrated Controller	05
3	Elevator Integrated Control Cabinet	07
4	Elevator Emergency Rescue Device	15
5	Elevator Control Board	23
6	Elevator Accessories	29

SHENYANG BLUELIGHT
DRIVE THE FUTURE

AWARDS & HONORS

All main products have obtained CE certification.

7 National innovation patents, more than 30 software copyrights,
more than 50 utility and design patents



IBL6 ELEVATOR INTEGRATED CONTROLLER

IBL6 is the new generation intelligent elevator integrated controller. It combines the functions of logical control and variable frequency drive. It has Advanced Technology, Optimal Performance, High Reliability, Easy to Use and many more excellent features.



Intelligent Control Leading the Future

1. Advanced technology

- Perfectly combines intellectual logic control and high performance VVVF drive to achieve complete integration.
- Adopts advanced vector control technology, demodulates motor with high precision, takes full advantage of motor capacity, improves elevator performance and riding comfort.
- Advanced space vector PWM algorithm, improves great efficiency than traditional sine/cosine PWM method and saves more energy
- Applied The STO(Safe Torque Off) Technology. When the elevator fails to stop, the STO function will be triggered, then the integrated controller stops the torque output to ensure the safety of the elevator and reaches the functional safety level to SIL3. At the same time, reducing the failure caused by the contactor running.

2. Optimal Performance

- Generates optimized speed curve based on target floor to achieve lift direct stop with high accuracy and efficiency.
- CAN BUS technology satisfies serial communication in high speed and reliability. Simplifies system wiring and extension.
- Compatible with wireless remote monitoring system on internet, convenient for remote commissioning guidance, maintenance and elevator monitoring.

3. Easy to Use

- Compatible with smart phone tuning with comprehensive information. Support parameters and error data remote transfer, online guidance, balance coefficient detection and other functions. Make the tuning process easy and efficient.
- Simple auto-tuning (self-learning) operations to get motor parameters and initial angle for both Rotating and Static methods.
- Fuzzy logic control for elevator start-up with non-load-compensation. Excellent comfort feeling even without weighting device.
- When working with Bluelight Synchronous traction machine, controller could use the information from its predefined machine model, which can save machine parameter input and auto-tuning process, improve the commissioning efficiency and maximize machine performance.

4. Highly Reliability

- Advanced two 32-bit CPU and a FPGA cooperation for complete elevator control to ensure high elevator safety and reliability.
- Redundancy design and full software-hardware protection to guarantee elevator safety and reliability.
- Professional EMC tested, enhanced anti-electromagnetic interference ability and suitable for complicated job site.
- Monitoring the cutting current from controller to traction machine every time when elevator stops.

Model Description

BL6 - U O 4 007 - N

BL6	U	O	4	007	N
Controller series	Controller Type	Protective structure	Maximum machine power	Voltage Level	Additional Type
Controller series	U: Integrated controller	C: Closed type	4: 380V	002:2.2kW	Null: Serial integrated controller with acrylic front plate or without front plate W: With Metal plate B: Parallel integrated controller C: Ultra-thin no case S: Small size integrated controller H: Villa integrated controller N: Plastic Case M: Modular Type integrated controller D: Single phase integrated controller E: STO integrated controller
				003:3.7kW	
				005:5.5kW	
				007:7.5kW	
				011:11kW	
				015:15kW	
				018:18.5kW	
	S: High-Performance inverter	O: Open Type	2: 220V	022:22kW	
				030:30kW	
				037:37kW	
				045:45kW	
				055:55kW	
				075:75kW	
				090:90kW	
110:110kW					

M Series Integrated Controller Dimension Table (400V)

Controller Model	Exterior Dimension (mm)		
	W	H	D
BL6-UO4005-NM	222	348	200
BL6-UO4007-NM			
BL6-UO4011-NM			
BL6-UO4015-NM			

Controller Model	Exterior Dimension (mm)		
	W	H	D
BL6-UO4018-M	280	418	203
BL6-UO4022-M			
BL6-UO4030-M	320	480	228
BL6-UO4037-M			
BL6-UO4045-M	441	650	324
BL6-UO4055-M			
BL6-UO4075-M			
BL6-UO4090-M	560	900	340
BL6-UO4110-M			

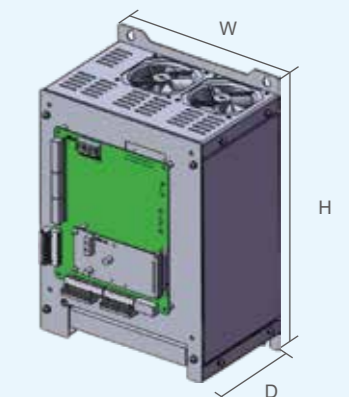
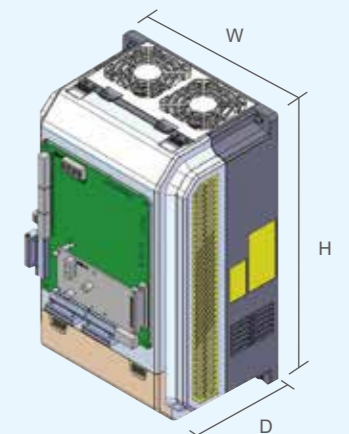

Specification

Model BL6-U□40□□□□	4002	4003	4005	4007	4011	4015	4018	4022	4030	4037	4045	4055	4075	4090	4110	
Max Motor Power(kW)	2.2	3.7	5.5	7.5	11	15	18.5	22	30	37	45	55	75	90	110	
Rated Output	Rated Output Capacity(KVA)	4.0	5.9	9	12	18	22	27	32	43	53	63	78	106	128	158
	Rated Output Current(A)	5.5	9	14	18	27	34	41	48	65	80	96	128	165	195	240
	Max Output Voltage(V)	3-Phase,AC380(Corresponding to the input/output)														
	Rated Frequency(Hz)	50														
	Max Output Frequency(Hz)	120														
Input Power	Rated Voltage(V)	3-Phase,AC380														
	Rated Frequency(Hz)	50														
	Rated Input Current(A)	6.5	11	17	22	32	41	49	58	78	96	115	147	190	210	260
	Allowable Voltage Fluctuation	±15%														
	Allowable Freq Fluctuation	±5%														

Model BL6-U□20□□□□	2002	2003	2005	2007	2011	2015	2018	2022	2030	2037	
Max Motor Power (kW)	2.2	3.7	5.5	7.5	11	15	18.5	22	30	37	
Rated Output	Rated Output Capacity(KVA)	4	7	10	14	20	27	33	40	44	55
	Rated Output Current(A)	11	17	25	33	49	66	80	96	115	145
	Max Output Voltage(V)	3-Phase, AC220 (Corresponding to the input voltage)									
	Rated Frequency(Hz)	50									
	Max Output Frequency(Hz)	120									
Input Power	Rated Voltage(V)	3-Phase, AC220V; Single phase, AC220V (Rated power 2.2kW ~ 11kW)									
	Rated Frequency(Hz)	50									
	Three Phase Rated Input Current(A)	12.5	21	27	40	52	68	92	110	125	160
	Single Phase Rated Input Current(A)	26	37	47	70	91					
	Allowable Voltage Fluctuation	+10%,-15%									
	Allowable Freq Fluctuation	Single Phase, 15kW input current:125									

Common Features and Specification for All Models

Basic Features	Elevator control mode	Simplex Collective, Duplex Collective, 3 ~ 8 Units Group Control
	Elevator Speed Range	0.5~4m/s
	Applicable highest floor	64
	Applicable elevator type	Passenger, Hospital, Panoramic, Goods, Villa Elevator
	Applicable motor	Geared Traction Machine, Gearless Traction Machine
	Communication mode	CAN Bus serial communication
	Leveling accuracy	≤3mm
	Drive Features	Control mode
Carrier Frequency		8kHz(6~12kHz adjustable)
Speed control range		1:1000
Speed Control accuracy		±0.05%(25°C±10°C)
Speed Response		30Hz
Torque limit		Yes(Set by parameter)
Torque accuracy		±5%
Frequency control range		0~120Hz
Frequency accuracy		Digital Ref: ±0.01%(-10°C+40°C)
Frequency Ref resolution		Digital Ref:0.01Hz
Output Freq resolution		0.01Hz
Overload capacity		150% Rated current 60s ; 180% Rated current 10s
Startup torque		180% Rated current 0Hz
Accel/decel time		0.001~600s
Main control function	Start without load compensation, battery operation, Auto tuning, Load compensation, Cooling fan control, Base block, Torque limit, CAN communication Ref, Acceleration/ Deceleration time, S curve acceleration/ deceleration, Monitor of traction machine for which electric current can be effectively interdict or not when the car stops, Internal brake, PG freq dividing output, Automatic fault retry, Automatic fault reset, Parameter copy.	

Common Features and Specification for All Models

Control Input/Output	OC input control power	Isolated external DC24V
	Relay output power	Isolated internal DC24V
	Low opto-isolated inputs	26-channel switches: rated load 7mA/DC24V, upper freq 100Hz
	High opto-isolated inputs	4-channel switches: rated load 8mA/AC110V, upper freq 100Hz
	Programmable relay output	12-channel switches: 9-channel: 1NO, contactor capacity: 5A/30VDC,5A/250VAC 3-channel: 1NO, contactor capacity: 8A/30VDC,10A250VAC
	CAN Communication Interface	2-Channel: DUPLEX/ group control, HOP/COP, REMOTE Wireless monitoring
	RS-232 Communication Interface	1-channel: Digital operator/PC monitoring/ Programmable interface
	Display	Digital Operator
Monitoring Software Interface		Display parameters, elevator running status, digital wave
Main Protection functions	Over Current	Stop when current exceed 200% rated output current
	Fuse	Stop at fuse brake at main circuit
	Overload Protection	Stop at 150% rated current 60 secs/180%rated current 10 secs
	Overvoltage Protection	Stops at DC bus voltage over 750V (400V drive) or 410V (200V drive)
	Undervoltage Protection	Stops at DC bus voltage under 380V(400V drive) or 190V (200V drive)
	Heatsink Overheat Protection	Protect by thermistors
	IGBT Internal Protection	IGBT over current/ overheat/ short circuit/ under voltage protection
	Motor Protection	Overload protection Stop
	Impact Restraining Circuit	Protect by Contactor Feedback
	Overspeed Protection	Protect at speed exceed the maximum allowable setting
	Speed Deviation Protection	Protect at speed deviation exceeds allowable value
	PG Fault Protection	Protect at PG disconnection/ phase error
	Auto-tuning Protection	Protect at auto-tuning fault
	Open-phase Protection	Protect at input/output phase lost
	Door Interlock Fault	Protect at door interlock circuit open when running
	Safety Circuit Fault	Protect at safety circuit open when running
	Brake Circuit Fault	No brake open feedback signal after output brake open command
	Leveling Zone Fault	Protect at leveling zone signal fault
	Output Contactor Fault	Protect at output contactor fault
	Running Time Protection	Protect at signal running time exceeds limit
Floor Counting Fault	Protect at floor counter fault	
Communication Interference Fault	Protect at communication interference fault	
Hoistway Parameter Learning Fault	Hoistway parameter learning fault protection	
Structure	Protection Degree	C:Closed IP20; O: Open IP00
	Cooling	Forced air cooling
	Installation	Placed in cabinet or Hanging installation
Using Ambiance	Ambient Temperature	-10°C~+40°C
	Humidity	5~95%RH,non-condensing
	Storage Temperature	-20°C~+60°C
	Application Situation	In doors, without direct sunlight, dust, corrosive/explosive gases, oil fog, vapor, water
	Altitude	<1000M
Vibration	10~20Hz,<9.8m/S2;20~50Hz,<2m/S2	

CAR DOOR INTEGRATED CONTROLLER

Bluelight Car Door

Integrated Controller

Adopts high performance inverter module and advanced SVPWM control method to optimize Car Door motor control ability. It increases the level of integration, reduces the cost and risk of failure.



Features

- ⊙ Adopts advanced vector control technology to increase running accuracy and stability.
- ⊙ Optimize speed curve to open and close door with ideal results.
- ⊙ Thinner designing with only 50mm height.
- ⊙ Compatible with most door machine types: asynchronous door machine without encoder, asynchronous door machine with encoder (full pulse), synchronous machine with encoder (full pulse).
- ⊙ Compatible with PWM type Z signal encoder
- ⊙ Complete protection features to guarantee driving safely.
- ⊙ Configurable I/O terminals for easy and feasible wiring.
- ⊙ Featured with LED screen and control buttons or can use Bluelight Digital Operator to control for easy operation on site.

Model Description

BL6 - DU 2 0P4 - S

BL6	DU	2	0P4	S
Model Series	Door Motor Controller	Voltage Level	Maximum Motor Power	Controller type
		2:220V	0P4:400W	S: Small Size Controller

Bluelight Door Motor Integrated Controller Spec List

Model	Exterior Dimension(mm)					Weight(kg)	Maximum Motor Power(W)	Voltage Level(V)
	W	H	D	W ₁	H ₁			
BL6-DU20P4-S	215	152	51	205	129	1.6	400	200 (Single phase)

Elevator Door Motor Integrated Controller Spec List

Model BL6-DU20P4S		20P4
Max Motor Power(W)		400
Output	Rated Output Capacity(kVA)	0.6
	Rated Output Current(A)	2.6
Input	Grid Voltage	1-Phase, AC220V,-15%~20%
	Grid Frequency(Hz)	50Hz±3Hz
Drive Features	Max Output Frequency(Hz)	99.00Hz
	Speed Range	1:50(Open Loop V/F Control),1:1000(Closed Loop Vector Control)
	Steady Speed	±0.5%(Open Loop V/F Control),±0.05%(Closed Loop Vector Control)
	Accuracy	0Hz-180%(Closed Loop Vector Control),1Hz-150%(Open Loop V/F Control)
	Frequency Resolution	0.01Hz
	Current Resolution	0.01A
	Carrier Frequency	2kHz~16kHz
Main Functions	For asynchronous motor, support run directly without encoder after filling motor basic parameters; For synchronous motor, support tune motor parameters and encoder zero position with load or without load.	
	Support AC PMSM (Permanent Magnet Synchronous Machine) closed loop vector control with normal ABZ encoder, encoder Open collector output or push-pull output mode. Signal Z support pulsed-mode or PWM mode	
	Rise torque automatically with open loop V/F control mode	
	Support door width self-learning function.	
	Support auto-demonstrating function	
Protection	Support obstruction auto-recognize function	
	Support controller over voltage protection, under-voltage protection, over current protection, Open-phase protection, inter phase short circuit protection and other functions.	
	Overload Protection	Stop at 150% rated current 60secs / 200% rated current 1secs
I/O	Relay Output	3 Outputs: using Changeover Contact Relay(NO+NC),3A/30VDC
	Optical Isolation Input	8 inputs with built-in current limiting resistor, DC 24V common anode power supply, distinguish polarity, and configurable by software.
Using Ambient	Cooling	Natural Cooling
	Protection Degree	IP20
	Ambient temperature Humidity	Ambient humidity under 90%(non-condensing), -20~40°C, Ventilation
	Vibration	>1G lower than 20Hz
	Application situation	Indoors, without direct sunlight, dust, corrosive/explosive gases
	Storage Situation	Clean/Dry/indoors
	Altitude	<1000M, please consider reduce power for higher than 1000m

ELEVATOR INTEGRATED CONTROL CABINET

STJ-WVF5 Series Elevator Integrated Control Cabinet

Has equipped iBL6 series Intelligent Elevator Core System (IECS) to combine logic control with VWF drive, it achieves efficiency by solid integration and intensive sharing of resource.

- To meet customer demands, the cabinet has different sizes to fit into applications no matter normal machine room, small machine room or machine roomless.
- The cabinet provides diversified interfaces to support wireless and wired remote monitoring, cell monitoring, elevator IC/ID card access management, sound broadcast and fire linkage control.
- Suitable for both geared and gearless traction machine.
- Supports elevator monitoring module over Internet: to collect data of elevator running, fault, maintenance and implement real-time elevator monitoring.

Control Cabinet Voltage: -AC3PH 220V+10%-15% 50Hz±5% •AC3PH 380V±15% 50Hz±5%

Model Description

SJT-WVF5 - I - B 4 007 - Y - 1

SJT-WVF5	I	B	4	007	Y	1
Model Series	Char/Meaning	Char/Meaning	Char/Voltage	Char/Power	Char/meaning	Char/Motor
SJT-WVF5	I/J: Modular	B: iBL6 series integrated controller	2: 220V	002:2.2kW	Y: Machine Room	1:Synchronous
				003:3.7kW		
				005:5.5kW		
				007:7.5kW		
				011:11kW		
				015:15kW		
	S: Standard	L: Yaskawa inverter +control board	4: 380V	018:18.5kW	W: Machine Roomless	0: Asynchronous
				022:22kW		
				030:30kW		
				037:37kW		
				045:45kW		
				055:55kW		
E: Economic	F: Fuji inverter + control board	4: 380V	075:75kW	B: Villa	0: Asynchronous	
			090:90kW			
			110:110kW			
F: Escalator	F: Fuji inverter + control board	4: 380V		B: Villa	0: Asynchronous	

1. Application Scope: simplex, duplex and group control for 3-8 elevators (with a group control board)
2. Speed Range: 0.25-4 m/s
3. Applicable Elevators: passenger elevators, freight elevators, bed elevators, residential elevators, panoramic elevators
4. Stops: <64
5. It is applicable to geared traction machines and gearless permanent magnet machines.

SJT-WVF5-I Series Modular Elevator Integrated Control Cabinet

Features

- Modular components for internal structure. Easy wiring, assembling and repairing.
- Internal interface board provides easy accessibility for hoistway cable and travelling cable. The simple plug-in type connection makes wiring mistake free and save time.
- Built-in over-voltage protection module to cut off power input immediately after neutral wire is broken. Ensure the safety of electric components.
- Built-in power source for brake system. Provides DC brake control which is more efficient and introduces less high frequency interference, heat or noise.
- Built-in DC24V switch power source, direct power output for Landing Call board, Car Board and so on. Provides up to 5A rated output current.
- Separate the brake system power source from the transformer, reduce its volume and weight. Thus, the size of the cabinet is reduced about 66% than normal cabinet.
- Light body design for the cabinet, minimize the amount of circuit breaker and contactor. The cabinet is wire socket groove free.



With Machine Room Machine Roomless

Model	SJT-WVF5-I Series Modular Elevator Integrated Control Cabinet (with machine room)	SJT-WVF5-I Series Modular Elevator Integrated Control Cabinet (machine roomless)
Power	3.7~22kW	3.7~22kW
Elevator Speed	0.25~4m/s	
Maximum Stops	64 stops	
Cabinet Dimension	450 X 235 X 900mm	350 X 235 X 1350 mm
Controller	iBL6 series integrated controller (M)	
Wiring Connection	Modular Interface board	
Voltage	AC 220V~240V(3.7~7.5kW)	
Traction Machine	Geared traction machine/Gearless permanent magnet synchronous machine	
Installation	On Floor/Hanging	On Floor

Note: The Maximum power level can be reached to 75kW. In case the cabinet size need adjusting at the same time.



SJT-WVF5-J Series Modular Elevator Integrated Control Cabinet

Features

- Adopts a brand new mechanical structure, breaking the shackles of traditional control cabinets where the all-in-one machine is only treated as a separate entity, and integrates the control cabinet with the all-in-one machine.
- Features a modular integrated structure. For an organic environment, a single cabinet is used; for an inorganic environment, a combination cabinet of an organic cabinet and an inorganic operation cabinet is used.
- Physical silent design reduces the noise generated by the contactor's suction and release actions. The ordinary contactor can also achieve good silent effects.
- Optional STO (Safe Torque Off) control board that meets SIL3 safety level, which can save customers from using operational contactors.
- Supports both pure hardware leveling board SJT-ZPC-V2 and programmable leveling board SJT-ZPC-P1.
- The control system supports communication-type absolute value encoders, and the communication protocol can be bound, which is designed for specific machines..
- The main control board integrates a wireless communication module, and on-site debugging only requires a mobile phone without any other special accessories.
- Equipped with an elevator IOT module, it can be directly connected to various local IOT platforms.
- The system provides a controllable holding brake power output, which automatically achieves a good starting comfort.

Power	1.1 ~ 22kW	Wiring Connection	Modular interface board
Elevator Speed	0.25 ~ 4m/s	Voltage	AC380V~415V(2.2 ~ 22kW)
Maximum Stops	64 stops	Speed Limiter Voltage	AC220V/DC24V optional
Cabinet Dimension	With Machine Room:240 X 200 X 930 mm	Traction Machine	Geared traction machine/Gearless permanent magnet synchronous machine
	Machine Roomless:240 X 200 X (930+750) mm	Installation	On Floor/Hanging/Split
Controller	iBL6 series integrated controller (M)		



Villa Elevator NS05 Separable Control Cabinet (200V/400V)

Features

NS05 Separable Control Cabinet is a modular design cabinet especially for villa and home elevators. We understand the installation restrictions of villa elevator projects, thoughtfully, we make the cabinet with the following features to meet your satisfaction:

- Modular components for internal structure. Easy wiring, assembling and repairing.
- Super thin and narrow, cabinet size is only 200*100*1145(mm), can fit in villa elevator project with little space.
- Building block type of installation method, the whole cabinet can separate into control cabinet and ARD cabinet. Both cabinets can install individually. This will reduce the control cabinet height to 815mm which can fit into even smaller spaces.
- Modular design makes wiring and commissioning more convenient. Moreover, the cabinet adopts standard modular interface board which is compatible with Bluelight regular modular control cabinet model. So for villa elevator and common passenger elevator can use same wiring cables.
- The system is equipped with a detachable operation box, which includes commonly used operating devices such as a maintenance switch, an emergency stop switch, a slow running button, an electric release button, an operator interface, and various reserved wire interfaces. Maintenance, debugging, and rescue operations can be completed without being restricted by the control cabinet being placed in the hoistway.
- The control system is equipped with the IECS system, making debugging more convenient and operation more comfortable. The TWCR remote monitoring system can also be optionally installed, providing additional safety and peace of mind.
- The unique suspension-type silent structure design and dedicated temperature-controlled fan speed control enable the control cabinet to operate quietly, significantly reducing operational noise.

Power	2.2 ~ 5.5kW	Wiring Connection	Modular interface board
Elevator speed	0.1~1m/s	Voltage	AC 220V~240V(2.2~3.7kW)
Maximum Stops	6 Stops	Traction Machine	Geared traction machine/Gearless permanent magnet synchronous machine
Cabinet Dimension	200 X 100 X 1145mm	Installation	On Floor/ Hanging/Split
Controller	iBL6 elevator integrated controller (special series)		

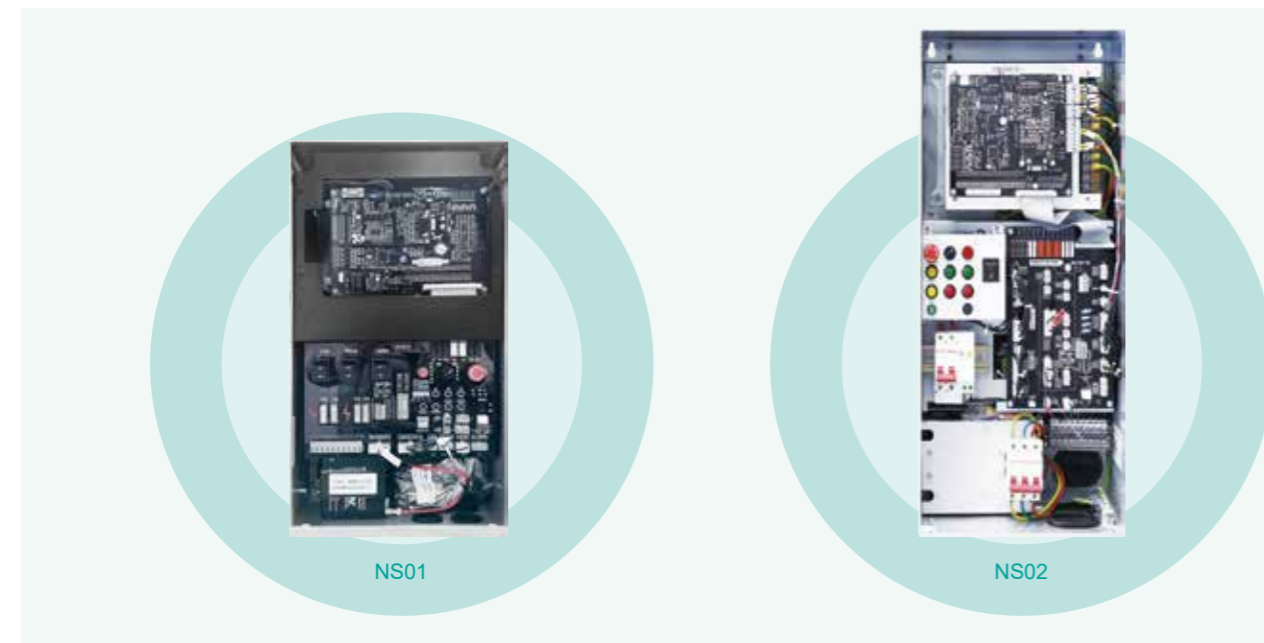

Villa Elevator Integrated Control Cabinet (NS01 / NS02)

Power	2.2kW/3.7kW	Wiring Connection	MIO series modular interface board (200V class)
Elevator speed	0.5m/s	Voltage	KIO series modular interface board (400V class)
Maximum Stops	6 Stops	Traction Machine	Gearless permanent magnet synchronous machine
Cabinet	300 X 170 X 550mm(200V Class)	Installation	On Floor/ Hanging
	320 X 190 X 650mm(400V Class)		
Controller	iBL6 series integrated controller (M)		

Villa Elevator Car Top Box SJT-CNT-3H00

Features

- ◎ The SJT-CNT-3H00 villa elevator car top box integrates the car top control board, car top interface board, emergency stop and maintenance switches, and other functions such as collecting car signals and outputting control signals.
- ◎ This car top box has a compact and aesthetically pleasing design, and can be wall-mounted or placed horizontally, making it suitable for installation on the top of villa elevator cars.



Production Size Dimension List

Model	Size Dimension(mm)						
	W	D	H	W ₁	W ₂	H ₁	D ₁
E2	310	82	140	325	340	190	101.2

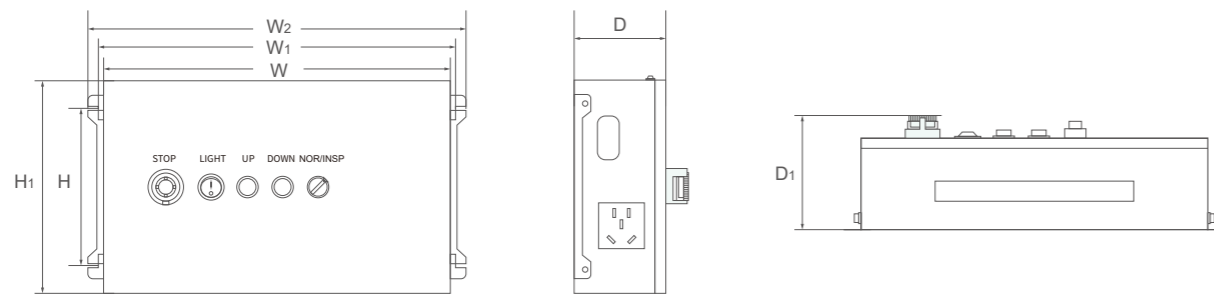

SJT-WVF5-I Series MRL Ultra-thin Elevator Control Cabinet (suitable for modernization)

Features

- ◎ Adopts the new generation iBL6 integrated controller, it has more complete and intelligent elevator logic control functions, and makes the variable frequency control more efficient.
- ◎ Modular components for internal structure. Easy wiring, assembling and repairing.
- ◎ Thanks for the simplicity of modular design, the control cabinet can be smaller, lighter and thinner, makes the installation unconventional easy and suitable for almost every application.
- ◎ Optimize heat transfer ability and fan control, smart noise reduction, adopts silent contactor to reduce operation noise effectively*.
- ◎ Equipped with emergency rescue device, during emergency situation, system enters rescue operation and professional personals can use the electric brake release buttons on operation panel to make the rescue.
- ◎ Satisfy GB7588-2003/2015 safety standard, include UCMP, car door/hall door short circuit detection, bypass and other functions that the new national standard requires.
- ◎ Compatible with full range peripheral produces, very feasible. With the assorting modular cartop box and car operation panel, the complete system is modular configured, thus highly increase the value for money for an excellent ridding experience.

* 5.5kW (AC220V~240V), 11kW (AC380V~415V) control cabinets are not applied with silent contactor.



Power	3.7~11kW	Wiring Connection	Modular interface board
Elevator Speed	0.25~4m/s	Voltage	AC 380V~415V(3.7~11kW)
Maximum Stops	64 Stops		AC 220V~240V(3.7~5.5kW)
Cabinet Dimension	350 X 145 X 1330mm	Traction Machine	Geared traction machine/Gearless permanent magnet synchronous machine
Controller	iBL6 series integrated controller (M)	Installation	On Floor

SJT-WVF5-S/E Series Elevator Integrated Control Cabinet (with machine room)

Power	3.7~22kW	Wiring Connection	Plug connector + terminal block
Elevator Speed	0.25~4m/s	Voltage	AC 220V~240V(3.7~7.5kW)
Maximum Stops	64 Stops		AC 380V~415V(5.5~22kW)
Cabinet Dimension	560 X 240 X 1200mm	Traction Machine	Geared traction machine/Gearless permanent magnet synchronous machine
Controller	iBL6 series integrated controller	Installation	On Floor/ Hanging



SJT-WVF5-S/E Series Elevator Integrated Control Cabinet (machine roomless)

Power	3.7~22kW	Wiring Connection	Plug connector + terminal block
Elevator Speed	0.25~4m/s	Voltage	AC 220V~240V(3.7~7.5kW)
Maximum Stops	64 Stops		AC 380V~415V(5.5~15kW)
Cabinet Dimension	380 X 195 X 1500mm	Traction Machine	Geared traction machine/Gearless permanent magnet synchronous machine
Controller	iBL6 series integrated controller	Installation	On Floor



Escalator Integrated Control Cabinet

Features

- ◎ SJT-WVF5-F Integrated Control Cabinet is the new generation high performance escalator control cabinet designed and manufactured independently by BlueLight . This control cabinet supports all functions for various escalator manufactures needs, and is suitable for automatic escalator and moving walks.
- ◎ Perfect combine of logic control and motor drive. Neat and affordable.
- ◎ Multiple power saving options.
- ◎ Featured with safety controller. Activates protection when Over-speed, Reverse-run and Step-lose. SIL3 safety level.



SJT-DW Series Freight Elevator Integrated Control Cabinet

The SJT-DW series freight elevator integrated control cabinet, equipped with BlueLight technology, is a special control system for freight elevators developed by our company in accordance with the national technical specifications for freight elevators. The product adopts a highly integrated design, which integrates the functions of multiple discrete components on a mainboard to meet the requirements of small size, full function, and smooth transport for freight elevators.

With its high reliability and high degree of intelligence, the product has won the trust of a wide range of users and has become the first choice for the production, transformation, and technological upgrading of freight elevators."



Features

Main control system function features:

- ◎ Support every kind of freight elevator which Maximum Speed <0.4m/s, Maximum stops < 16 and motor power <4.5kW.
- ◎ The hoistway cables are connected in an expanded and cascaded manner, featuring easy installation, unified cable format, and easy expansion.
- ◎ The system supports both manual single-door opening and pass-through door opening, and it also supports the function of an electromagnetic lock
- ◎ Special motor circuit breakers are used for operation, providing reliable short-circuit and overload protection for the motor.
- ◎ The built-in power phase sequence detection and protection circuit can stop the elevator when there is a power phase loss or phase error.
- ◎ The system has a comprehensive fault protection mechanism, which can accurately detect and stop the elevator to protect against safety circuit failures, communication failures, brake circuit disconnections, short circuits, and other faults.
- ◎ The control cabinet adopts a modular design, making it more convenient for maintenance and replacement.
- ◎ The control system has a high level of integration and intelligence, a compact structure, and a small appearance, making it easy to install on site and simple and quick to debug and use.
- ◎ It has passed the safety circuit type test certification.

Landing Call system function features:

- ◎ Supports two display modes: single-dot matrix and double-dot matrix.
- ◎ Supports door zone signals installed at floor landings.
- ◎ Supports electric lock input.
- ◎ Supports displaying arbitrary character for floor number, direction, fault, and maintenance status.
- ◎ Supports door open button input.

Model Description

SJT - DW - U4 02 A - 01 *

SJT	DW	U4	02	A	01	*
Model Series	Char/Meaning	Char/Voltage Level	Char/Power	Char/Meaning	Char/Meaning	Char/Meaning
Model	DW: Freight Elevator Integrated Control Cabinet	400V Class	03:3.7Kw 02:2.2Kw	A:Single Speed	01:Single-door 02:Pass-through door	Null: Standard Other Char: Customize Product

SJT-DW Series Freight Elevator Integrated Control Cabinet Specification List

Model	U402A	U403A
Max Adopted Power (kW)	3.0	4.5
Rated Output Current(A)	5~8	8~12
Maximum Output Voltage(V)	3-phase,AC380(corresponding input voltage)	
Rated Frequency(Hz)	50	
Rated Voltage(V)	3-phase,AC380	
Rated Frequency(Hz)	50	
Rated Input Current(A)	5~10	8~14
Allowable Voltage Fluctuation	+20%,-15%	
Allowable Freq Fluctuation	±5%	
Elevator Control Method	Button Control	
Elevator Speed Range	0.4m/s	
Maximum Stops	≤16 Stops	
Adoptable Elevator Type	Freight Elevator	
Electric Lock	DC24V < 2.5A	

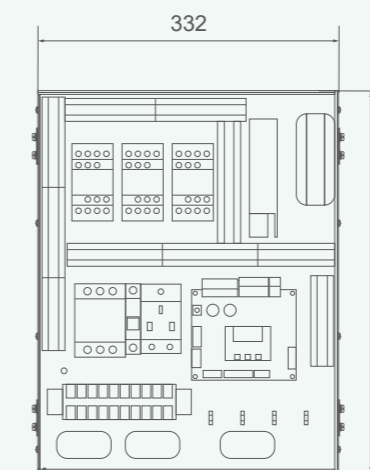

Front Size Dimension

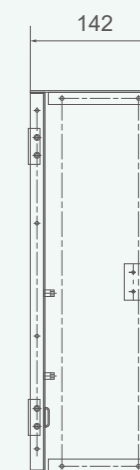

Side Size Dimension

ELEVATOR EMERGENCY RESCUE DEVICE

Electric Brake Release Device

Features

- For control cabinet has no door interlock contactor emergency stop contactor, the door lock circuit contacts can directly connect to the door lock detection terminal on electric brake release device. cost-effective and reliable.
 - Battery power output terminals are provided, which are equipped with exit terminals of door area indicator lights and button exit terminals.
 - Battery bin design, do not disassemble the machine, push the back battery bin cover plate, you can easily realize the battery replacement and maintenance;
 - PN, PT and PF models all use emergency power supply. When used with BL VM3 motherboard, the LED digital block on the motherboard can display the speed and direction of car sliding during emergency rescue.
 - PT model, the output power of 24V power supply is increased to 50W, It can directly supply power to the entire 24V system during operation and the door zone switch power no longer needs a separate wiring.
 - PF model split product adopts battery and product separation design, the product is maintenance-free, easy to meet the needs of long-term storage or long-distance transportation (such as overseas site), After arriving at the site, the battery can be purchased and installed independently, eliminating the inconvenience of regular charging and discharging management of the battery.
- Otherwise, the height of device is only 108mm which can fit into ultra-thin control cabinet.

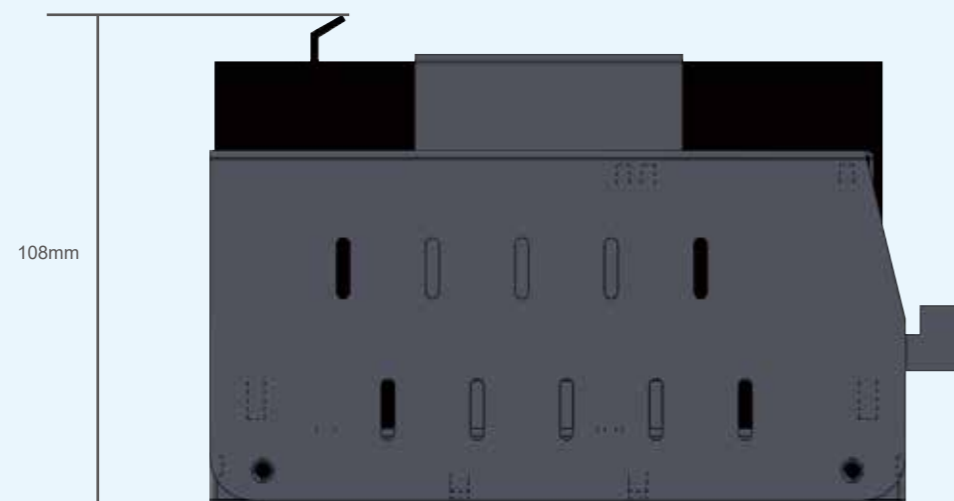

Model Description

SJT - EPB - 110 - PF

SJT	EPB	110	PF
Model Series	Electric Brake Release Product	Open Brake Full Voltage	Power Supply Output Function
		110:110V	NN: Integrated body, plastic case without power supply output
			PN: Integrated body, plastic case with power supply output
		220:220V	PT: Integrated body, plastic case with power supply output, expandable
			PF: separate body with metal case

Electric Brake Release Device Specification List

Model	SJT-EPB110/PF/PN/PT	SJT-EPB220/PF/PN/PT	
	SJT-EPB110/NF/NN	SJT-EPB220/NF/NN	
Max Adapted Brake Power(W)	450	450	
Output	Rated Output Voltage(V)	110	220
	Rated Output Current(A)	4	2
Input	Power Grid Voltage	220V±15%	
Battery Specification	Rated Voltage	12V	
	Rated Capacity	7AH	
	Constant Current Charge Current	1A	
	Constant Current Charge Time	4h	
	Trickle Current Charge Voltage	13.8V	
Control Features	Full Voltage/Open Brake Voltage	110V	220
	Half Voltage/Holding Brake Voltage	75V	150
	Battery Under-voltage Protect Voltage	10V	
	Single Run Time	5min	
	Output Voltage Ripple Wave	<5%	
	Efficiency	>90%	
	DC5V	Maximum Current 300mA	
	DC13V	Maximum Current 120mA	
DC5.2V	Maximum Current 100mA		
Protection	Over Current Protection	Protect When Battery Output Current Exceed Limit	
	Under Voltage Protection	Protect When Battery Voltage is under 10V	
	Short Circuit Protection	Protect When Short Circuit of Open-Brake Output	
I/O	Door Zone Input	Automatically stop Open-Brake Output when elevator enter door zone	
	Door Lock Input	Automatically stop Open-Brake Output when door circuit is cut off	
	Button Input	Extra Button Interface, More Flexible	
Environment	Cooling Type	Natural Air Cooling	
	Protection Level	IP20	
	Environment Temperature & Humidity	Below 95%RH, non-condensing -15°C ~ +40°C, well-ventilated	
	Vibration	Beyond 1G while under 20Hz	
	Application	In doors, altitude<1000m, without direct sunlight, dust, corrosive/explosive gases, oil fog, vapor, water dripping, or salty substances	

Automatic Rescue Device (ARD, Output Single-phase)

Features

- Most advanced technology can support rescue operation longer: advanced direct current boost and full-bridge inverter circuit technology, high conversion efficiency, low power loss and support rescue operation much longer than ordinary.
- Intelligent battery recharge/discharge management to extend battery life: Defined recharging power input circuit for under voltage and over voltage protection; Repeat display recharging battery voltage and capacity in real time, monitoring the battery status all the time; smart automatic switch between constant voltage charging, constant current charging and trickle charging; battery low voltage protection and output under voltage protection effectively prevent battery over discharge and tremendous increase battery life;
- Full modular design for simple application: built-in power source switching functions, no auxiliary circuit is needed, simple connect and use; Fast battery install and remove, easy to replace on site ;
- Available in two output voltage levels: single-phase AC220V and AC380V, users can select accordingly on project.

Isolated Model(G Series):

- The system has strong overload capacity and the output voltage automatically drops when overloaded, and the system no longer reports faults.
- The system has significantly enhanced anti-capacitive load impact capacity.
- When outputting at 380V, in addition to outputting 380V on R/S, an additional 220V can be output on R/N.
- The number of power devices is reduced, reducing the number of fault points

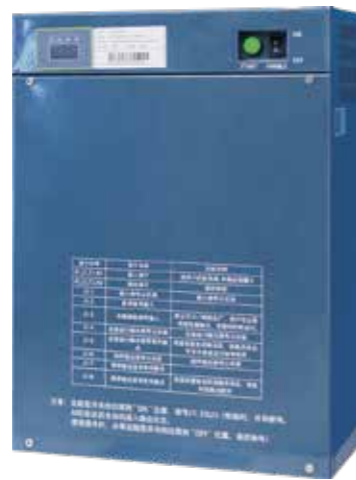

Standard



G Series

Model Description

ARD - 4 - S - 15 - A1 - G

ARD	4	S	15	A1	G
Automatic Rescue Device	Recure Output Voltage Level	Voltage Type	Maximum Adaptable Machine Power	Product Model	Technology Type
	4:380V Class	S: Single-phase AC output, with three-phase 380V grid input	03:3.7kW and below	A1: regular type	G: Isolated Model
			05:5.5kW and below		
			07:7.5kW and below		
	2: 220V Class	D: Single-phase AC output, with three-phase 220V grid input	11: 11kW and below	B1: power enhanced type	
			15: 15kW and below		
			18: 18.5kW and below		
	E: Single-phase AC output, with single-phase 220V grid input	22: 22kW and below	N1: no battery (Prepared by user)	Null: Standard	
		30: 30kW and below			
		37: 37kW and below			

Product Dimension List

Model	Size (mm)						Installation
	W	D	H	H ₁	A	B	
E1	320	140	425	488/470	290	463	Hanging/On Floor
E2	335	160	500	563/545	290	540	
E3	350	170	560	623/605	290	600	

Automatic Rescue Device (ARD) provide 2 method for installation: On floor and Hanging , The body size is E1 to E3.

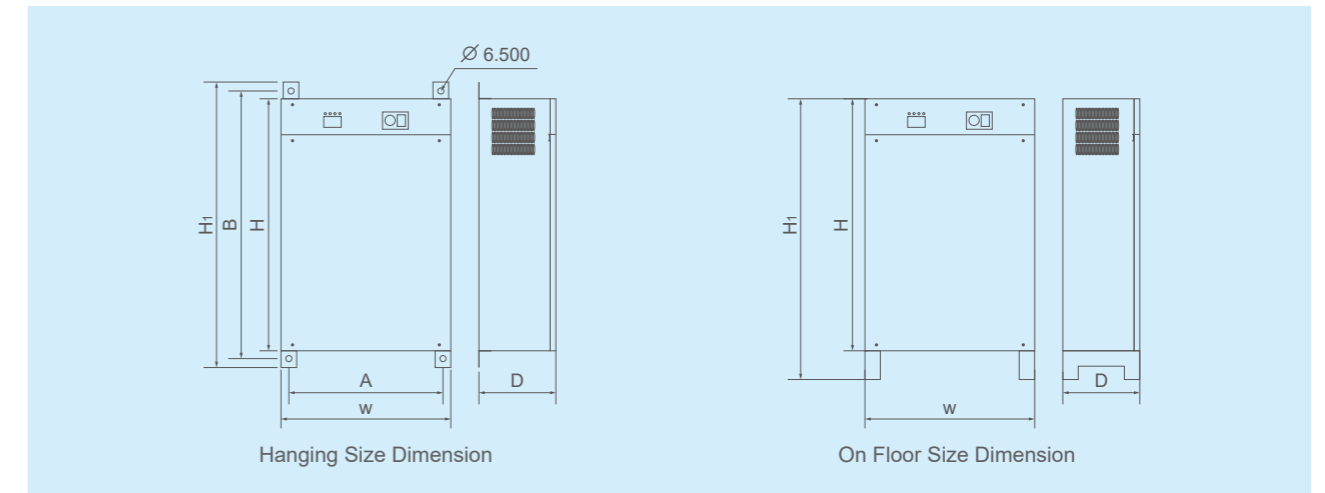

Model	Size (mm)						Installation
	W	D	H	H ₁	A	B	
E4	330	159	445	390/330	360	285	Hanging/ On Floor

Automatic Rescue Device (ARD) provide 2 method for installation: On floor and Hanging , The body size is E4.

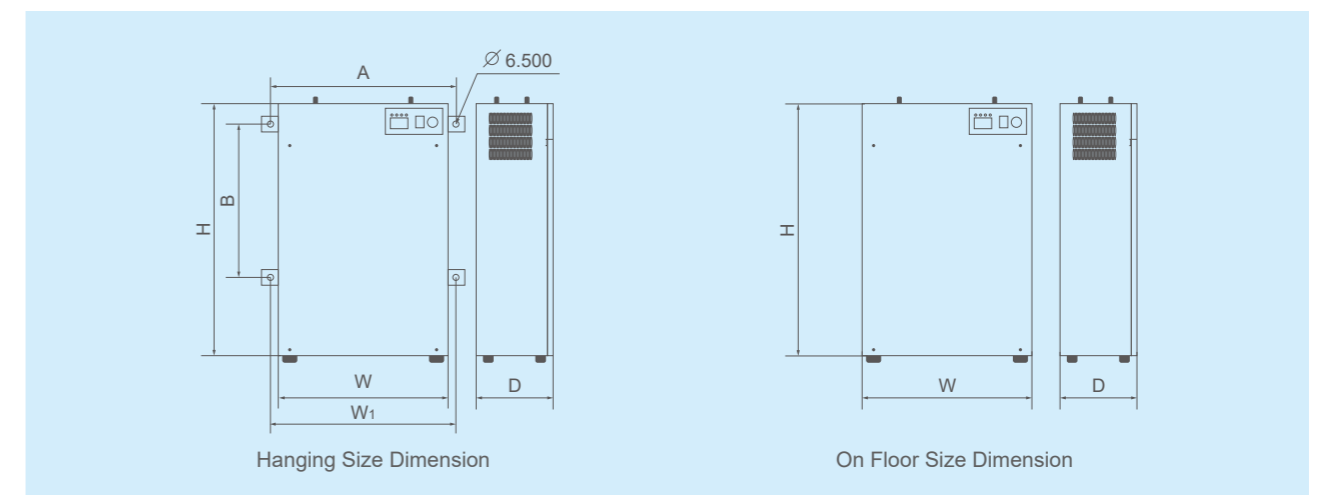

Automatic Rescue Device (ARD, Output Single-phase) Specification List

Standard Specification List		
Product Type	A1/B1	Regular/Enhanced
	N1	No battery(Prepared by user self)
Control Features	Recommended Elevator self-recure speed	1/12 Elevator rated running speed
	Single Running Time	5min
	Output Voltage Waveform	Sine Waveform
	Efficiency	>90%
Environment	Cooling Type	Natural/Forced Air Cooling
	Protection Level	IP20
	Environment Temperature & humidity	Below 95%RH, non-condensing -15°C ~ +40°C, well-ventilated
	Vibration	Beyond 1G while under 20Hz

E Series Model-Selection List(Grid Power Supply Type: 1-PH AC220V, 1-PH AC220V is provided under rescue)						
ARD Model	Rescue Voltage Level	Max Motor Power	A-Type Max Rated Elevator Load	B-Type Max Rated Elevator Loads	Output Power	Size
ARD2E03	1-PH AC220V	3.7kW	630 kg	800 kg	0.4 kW	E1
ARD2E05	1-PH AC220V	5.5kW	1150 kg	1350 kg	0.6 kW	E1
ARD2E07	1-PH AC220V	7.5kW	1150 kg	1350 kg	0.6 kW	E1
ARD2E11	1-PH AC220V	11kW	1600 kg	-----	0.8 kW	E2

G Series Model-Selection List(Grid Power Supply Type: 3-PH AC380V, 3-PH AC380V and 1-PH AC220V are provided under rescue)						
ARD Model	Rescue Voltage Level	Max Motor Power	A-Type Max Rated Elevator Load	B-Type Max Rated Elevator Loads	Output Power	Size
ARD4S05A1-G	1-PH AC380V	5.5kW	630 kg	800kg	0.4 kW	E4
	2-PH AC220V					
ARD4S07A1-G	1-PH AC380V	7.5kW	1150 kg	1350 kg	0.6 kW	E4
	2-PH AC220V					
ARD4S11A1-G	1-PH AC380V	11kW	1150 kg	1350 kg	0.6 kW	E4
	2-PH AC220V					
ARD4S15A1-G	1-PH AC380V	15kW	1150 kg	1350 kg	0.6 kW	E4
	2-PH AC220V					
ARD4S18A1-G	1-PH AC380V	18.5kW	1150 kg	1350 kg	0.6 kW	E4
	2-PH AC220V					

D Series Model-Selection List(Grid Power Supply Type: 3-PH AC220V, 1-PH AC220V is provided under rescue)						
ARD Model	Rescue Voltage Level	Max Motor Power	A-Type Max Rated Elevator Load	B-Type Max Rated Elevator Loads	Output Power	Size
ARD2D03	1-PH AC220V	3.7kW	630 kg	800 kg	0.4 kW	E1
ARD2D05	1-PH AC220V	5.5kW	1150 kg	1350 kg	0.6 kW	E1
ARD2D07	1-PH AC220V	7.5kW	1150 kg	1350 kg	0.6 kW	E1
ARD2D11	1-PH AC220V	11kW	1150 kg	1350 kg	0.6 kW	E1
ARD2D15	1-PH AC220V	15kW	1150 kg	1350 kg	0.6 kW	E1
ARD2D18	1-PH AC220V	18.5kW	1600 kg	-----	0.8 kW	E2
ARD2D22	1-PH AC220V	22kW	1600 kg	-----	0.8 kW	E2

4S Series Model-Selection List(Grid Power Supply Type: 3-PH AC380V, 1-PH AC380V is provided under Rescue)						
ARD Model	Rescue Voltage Level	Max Motor Power	A-Type Max Rated Elevator Load	B-Type Max Rated Elevator Loads	Output Power	Size
ARD4S03	1-PH AC380V	3.7kW	630 kg	800 kg	0.4 kW	E1
ARD4S05	1-PH AC380V	5.5kW	1150 kg	1350 kg	0.6 kW	E1
ARD4S07	1-PH AC380V	7.5kW	1150 kg	1350 kg	0.6 kW	E1
ARD4S11	1-PH AC380V	11kW	1150 kg	1350 kg	0.6 kW	E1
ARD4S15	1-PH AC380V	15kW	1150 kg	1350 kg	0.6 kW	E1
ARD4S18	1-PH AC380V	18.5kW	1150 kg	1350 kg	0.6 kW	E1
ARD4S22	1-PH AC380V	22kW	1600 kg	-----	0.8 kW	E2
ARD4S30	1-PH AC380V	30kW	1600 kg	-----	0.8 kW	E2
ARD4S37	1-PH AC380V	37kW	1600 kg	2000kg	1.3 kW	E3

2S Series Model-Selection List(Grid Power Supply Type: 3-PH AC380V, 1-PH AC220V is provided under Rescue)						
ARD Model	Rescue Voltage Level	Max Motor Power	A-Type Max Rated Elevator Load	B-Type Max Rated Elevator Loads	Output Power	Size
ARD2S03	1-PH AC220V	3.7kW	630 kg	800 kg	0.4 kW	E1
ARD2S05	1-PH AC220V	5.5kW	1150 kg	1350 kg	0.6 kW	E1
ARD2S07	1-PH AC220V	7.5kW	1150 kg	1350 kg	0.6 kW	E1
ARD2S11	1-PH AC220V	11kW	1150 kg	1350 kg	0.6 kW	E1
ARD2S15	1-PH AC220V	15kW	1150 kg	1350 kg	0.6 kW	E1
ARD2S18	1-PH AC220V	18.5kW	1150 kg	1350 kg	0.6 kW	E1
ARD2S22	1-PH AC220V	22kW	1600 kg	-----	0.8 kW	E2
ARD2S30	1-PH AC220V	30kW	1600 kg	-----	0.8 kW	E2
ARD2S37	1-PH AC220V	37kW	1600 kg	2000kg	1.3 kW	E3

Automatic Rescue Device (Output 3-phase)

Features

- Strong overload resistance, the output voltage automatically decreases during overload, and the system will not report a fault.
- Significantly enhanced anti-capacitive load impact capability.
- The output power is three-phase 380V, which is more convenient to connect, and there is no need for a phase sequence relay during rescue operations: Regular Type: elevator system needs to have emergency rescue operation function. Heavy-Load Type: the emergency rescue operation function is not required.
- The number of power devices is reduced, reducing the number of potential failure points.
- The external interface is compatible with the output of single-phase ARD products.



Automatic Rescue Device provides 2 installation Method: On floor and Hanging.

The Size is E1 to E2:

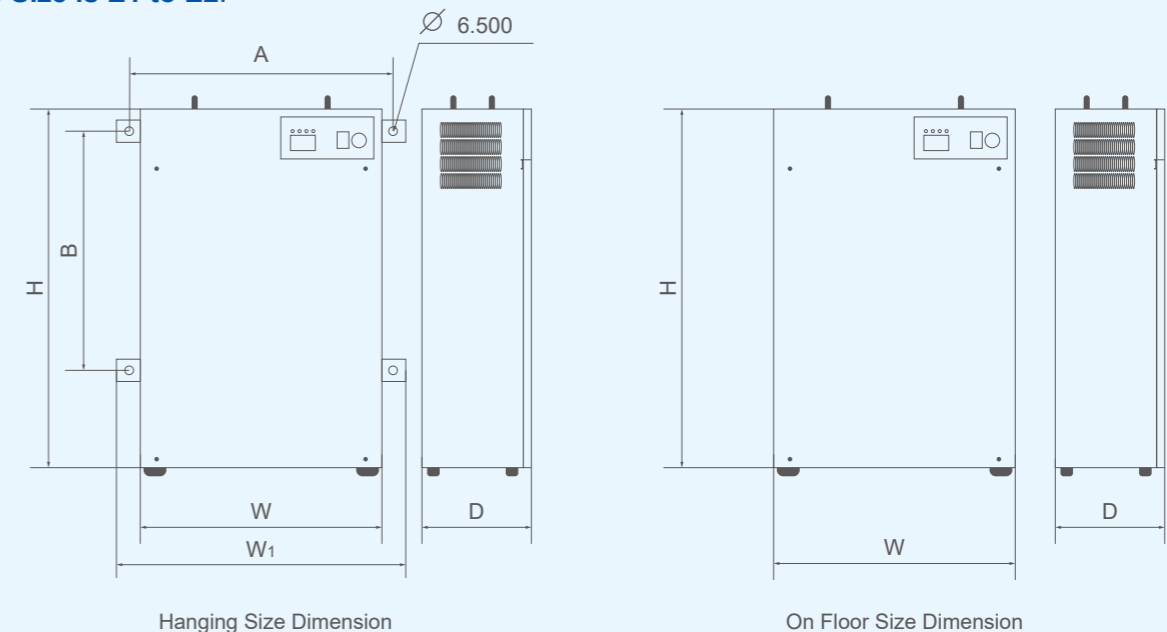

Model Description

ARD - 3 - P - 15 - A

ARD	3	P	15	A
Automatic Rescue Device	Rescue Output Voltage Level	Voltage Type	Max Motor Power	Product Type
Automatic Rescue Device	3: 380V Three-phase Output	4: 380V Class	005: 5.5kW and below	A: With Battery
			007: 7.5kW and below	
			011: 11kW and below	
			015: 15kW and below	
		2: 220V Class	018: 18.5kW and below	
			022: 22kW and below	
			030: 30kW and below	

Product Dimension

Model	Size (mm)						Installation
	W	D	H	W ₁	A	B	
E1	360	169	505	420/360	390	330	Hanging/ On Floor
E2	405	169	530	465/405	435	355	

Automatic Rescue Device (ARD, 3-Phase output) Specification List

ARD Model	Rescue Voltage Level	Max Motor Power	A-Type Max Rated Elevator Load	Output Power	Size
ARD3P07A	3-PH AC380V	7.5kW	1150 kg	0.7 kW	E1
ARD3P11A		11kW	1150 kg	1.0 kW	
ARD3P15A		15kW	1150 kg	1.0 kW	
ARD3P18A		18.5kW	1150 kg	1.0 kW	
ARD3P22A		22kW	1350 kg	1.2 kW	E2
ARD3P30A		30kW	1350 kg	1.2 kW	
ARD3T05A		5.5kW	800 kg	1.0 kW	E1
ARD3T07A		7.5kW	1150 kg	1.2 kW	
ARD3T05A		11kW	1150 kg	1.2 kW	
ARD3T05A		15kW	1150 kg	1.4 kW	
ARD3T05A		18.5kW	1150 kg	1.4 kW	
ARD3T05A		22kW	1150 kg	1.8 kW	
ARD3T05A		30kW	1150 kg	1.8 kW	

ELEVATOR CONTROL BOARD

Bluelight 7-inch True-color Display with Voice Announcer

BL2000-HEH-M7

It displays information including current floor, running direction, date and time, special states (inspection, fire, etc.). It has built-in voice module and features with full functions of voice announcer

Features

- Available in horizontal and vertical display, Chinese and English language, both can change in setting menu.
- With built-in speaker and features with voice announcer functions, can play background music, greeting words, "Ding Dong", sounds, floor announcing, floor states such as fire, overload and others;
- Can repeat display background pictures (5 pictures of BMP file type, repeat display). Customer LOGO, date, week displays can set by buttons, very fast operations.
- 128MB memory space, can upload pictures using a USB drive, simple way to change display content.



Bluelight 10.4-inch Touch Screen Operation Panel

Bluelight 10.4-inch Touch Screen Operation Panel (model: SJT-ETOUCH-104-LG)

The up-part features car display functions with customize pictures; the underpart contains car call buttons. Available in maximum 10 buttons including floor selections and functional keys.

Features

- Functional keys including: open door, close door, close door delay, alarm, intercom; Close door delay, alarm and intercom can set to not display for total 8 stops buildings.
- Floor key display can set on location, available in 3-digit (example 12A).
- Two channels independent relay normal open output to control intercom and alarm buttons;
- Adopt 485 communication interface, compatible with CAN-232/485 protocol translate board, can apply for all Bluelight general protocol/special protocol control systems.



TFT True-Colour LCD Landing Call Board

The TFT LCD display is equipped with 24-bit true-color screen, High performance processor, large memory SDRAM and NANDFLASH. In addition to the regular elevator display functions, it is also featured with time and date display as well as pictures and advertisements.

Features

- Elevator Running State Display: elevator moving direction, stops floor (1-3 digits), characters "-", "0-9" and "A · Z".
- Horizontal and vertical display options.
- Up and down landing calls register and answering indication, with calling button stuck detecting functions.
- Changeable background picture to display photos and advertisements as desired.
- Automatically switch off when the elevator is locked.
- Display elevator states (Inspection, Fire, Overload, etc.) in both English and Chinese.

Specifications

- Powered by ADSTAR processor, operation frequency is 108MHZ
- 24-bit color range TFT LCD screen. The series have screen sizes of 4.3-inch, 5.6-inch and 8-inch.
- Large memory NANDFLASH to store pictures. High speed SDRAM to boost display quality.
- CAN BUS communication, fully compatible with Bluelight Serial Communication systems.

5.6-inch TFT True-Color LCD Screen BL2000-HEH-M2.3

Features

- Multiple background pictures repeat display, users can upload pictures by simple operations.
- 5.6-inch 24-bit TFT LCD Screen.



8-inch TFT True-Color LCD Screen BL2000-MBQ-V4.1

Features

- Background pictures repeating display. Users can upload pictures and set the number of displaying pictures by simple operations.
- 8-inch 24-bit TFT LCD Screen.



4.3-inch TFT LCD Screen BL2000-HEH-L4

Features

- Multiple background pictures repeat display, users can upload pictures by simple operations.
- 4.3-inch 24-bit TFT LCD Screen.



Elevator Car Call Extension Board

BL2000-CEB-V2

BL2000-CEB-V3

- Application Scope: simplex, duplex and group control (with group control board)
- Applicable Elevators: passenger elevators, freight elevators, bed elevators, residential elevators, panoramic elevators
- Stops: <64
- Floor extension for car call and register. Can interconnect of the Car Board and one another Car Call Extension Board. Cooperates with Bluelight Car Communication Board or Car Command Board.

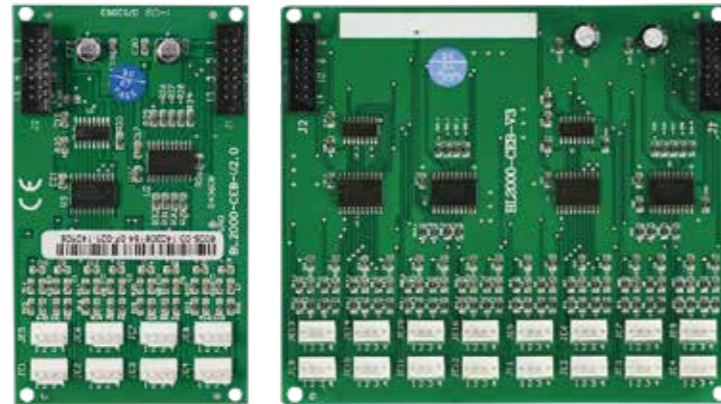

BL2000-CEB-V2

BL2000-CEB-V3

Villa Elevator Specific Car Call Board

BL2000-ZLB-H6

- Applicable Elevator: Villa Elevator
- PCB Size: 100 X 80mm;
- Stops: 6 Stops and below;
- A Small Size Car Call board for villa elevator using requirements, collecting car call input signal, open/close door input signals, and output the floors register indications.

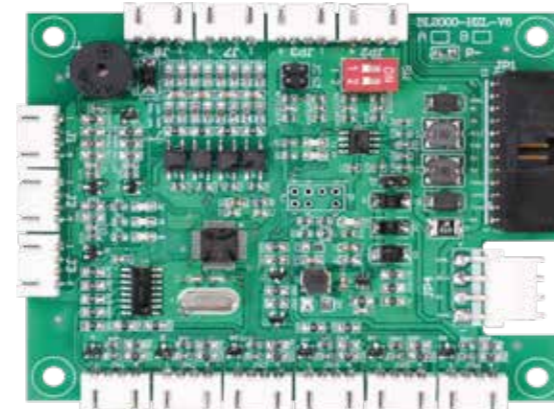

Elevator Serial Communication Car Call Board

BL2000-CZB-V10

- Application Scope: simplex, duplex and group control (with a group control board)
- Applicable Elevators: passenger elevators, freight elevators, bed elevators, residential elevators, panoramic elevators
- Stops: <64
- Collects information such as car call input signals, open/close door signals, door state data, weighting device data and maintenance box data.
- Outputs the door control signals and called floors register indications.



Elevator Group Control Board

BL2000-QKB-V2

- Imple Configuration: only one group control board is needed for a set of group elevators. CAN BUS communication.
- Max. number of elevators: 8
- Max. stops: 64
- Balanced Running Mode: optimal elevators allocation to minimize users' waiting time. Elevators response fast and appropriate.
- Peak Hour Mode: Satisfy elevator demands in peak hours for public places such as office buildings.
- Idle Running Mode: evenly distribute elevators at designated floors in idle time to minimize the reaction time of answering landing calls.
- Automatic Removal of Reluctant Elevator: when the calling elevator is currently occupied, automatic arrange another elevator to respond, fast react to landing calls.



Elevator Destination Floor Group Control Board

BL2000-QKB-V3

- Max. number of elevators: 8
- Max. stops: 32
- Balanced Running Mode: optimal elevators allocation to minimize users' waiting time or minimize transfer times.
- Peak Hour Mode: Satisfy elevator demands in peak hours for public places such as office buildings.
- Idle Running Mode: evenly distribute elevators at designated floors in idle time to minimize the reaction time of answering landing calls.
- Automatic Removal of Reluctant Elevator: when the calling elevator is currently occupied, automatic arrange another elevator to respond, fast react to landing calls.
- Simple Structure: Dual-channel CAN-BUS bus, one connects to the group control elevators, and the other connects to the destination floor selectors on each floor.
- Busy factor adjustment: used to balance the load capacity of each elevator and improve the overall operational efficiency.



Destination Floor Selector

SJT-MBC-V1 (Button)

- 5.6-inch true color LCD display with large font and direction indicator.
- Enable passenger input mode to improve elevator efficiency.
- High-reliability 4 x 4 metal keypad with buzzer prompt
- Stainless steel casing, wall-mounted installation



SJT-MBC-V1



SJT-EPAD-097-QK

SJT-EPAD-097-QK(9.7-inch touchpad)

- 9.7-inch touchpad screen display with large font and direction indicator;
- Enable passenger input mode to improve elevator efficiency
- Can switch Chinese/English by the setting UI, but need using SJT-CAN-232/485-V1 protocol convert board .

Segmental LED Display/Hall-Call Board

BL2000-HEH-Q1-A / B

- ◎ PCB board Size:136 X 154 X 13.5mm;
- ◎ Display Mode:Horizontal display
- ◎ Display Color:

Model	Color
BL2000-HEH-Q1-A	Blue background with white letters
BL2000-HEH-Q1-B	Black background with white letters

BL2000-HEH-P1-A / B

- ◎ PCB Board Size:176 X 126 X 13.5mm;
- ◎ Display Mode: portrait display
- ◎ Display Color:

Model	Color
BL2000-HEH-P1-A	Blue background with white letters
BL2000-HEH-P1-B	Black background with white letters



Safety Circuit Board

SJT-ZPC-V2 A

- ◎ Pure hardware safety circuit board;
- ◎ Can realize UCMP function;
- ◎ Can realize advance door opening, re-leveling function;
- ◎ Can realize door lock short circuit detection function;
- ◎ Can realize the relay only action at the target floor.

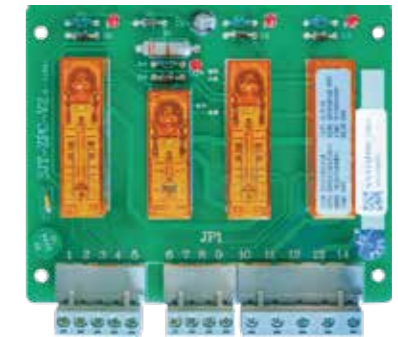

SJT-ZPC-V2 A

SJT-ZPC-P1

- ◎ Able to self-detect faults and enter a safe state
- ◎ Can completely replace pure hardware safety circuit boards
- ◎ Contains programmable devices and is certified by PESSRAL (SIL2 level)
- ◎ Can detect any form of door lock short circuit and report faults;
- ◎ The target layer action of the relay extends its service life
- ◎ Uses CAN communication to provide control and feedback signals, saving IO ports;
- ◎ The safe door zone signal is a control signal, and the door zone switch current requirement is small



SJT-ZPC-P1

Ultra-Thin Calling Board

BL2000-HEH-N4 Series

- ◎ PCB board Size: 134 X 72 X 7.5mm
- ◎ Display Mode: Segment display
- ◎ Display Color: Black background with white letters.

Brand new design product from Bluelight with better display experience and longer life.



BL2000-HEH-N4 Series

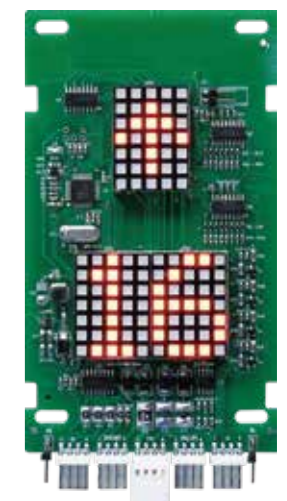

BL2000-HAH-N6 Series

BL2000-HAH-N6 Series

- ◎ PCB Board Size: 134 X 76 X 7.5mm
- ◎ Display Mode: Dot Matrix Display
- ◎ Display Color:

Model	Color	Shape	Customization
BL2000-HAH-N6.X-A1	Red	Round Dot Matrix	Need
BL2000-HAH-N6.X-B1	Orange	Round Dot Matrix	Need
BL2000-HAH-N6.X-A2	Red	Square Dot Matrix	No Need
BL2000-HAH-N6.X-B2	Orange	Square Dot Matrix	Need

ELEVATOR ACCESSORIES

Shenyang Bluelight can customize exclusive elevator IOT and smart elevator software and hardware products for you, including elevator cloud monitoring platform, elevator cloud app, elevator cloud smart screen, and elevator cloud facial recognition touch all-in-one machine. We aim to add value to your products, save you money, and relieve your worries. This is how we, the Bluelight team, realize our own value.



Elevator Cloud Monitoring Center

The Elevator Cloud is deployed on Alibaba Cloud and uses the MQTT protocol, which is the mainstream messaging protocol in the Mobile Internet (MI) and Internet of Things (IoT) fields, for real-time message communication. It can support concurrent messaging for millions of devices, making it a next-generation intelligent elevator online management system. The system is a deep application of IoT communication, big data fault prediction, machine vision, and other technologies in the field of elevator data and video monitoring. It realizes functions such as trapped passenger recognition, proactive alarm, intelligent comfort, fault warning, facial recognition, QR code access, visual intercom, voice station announcement, multimedia advertising push, local weather forecast, and property message notification.

Elevator Cloud APP



- Elevator initial installation info input
- Remote Car Video Intercom
- Remote Read and Write of Equipment Parameters
- Elevator Information Management
- Maintenance Task Expiration Reminder
- Remote Monitoring Elevator Status
- QR code Elevator Access Management
- Real-time Elevator fault alert
- Face Recognition data collection

Elevator Cloud Smart Screen

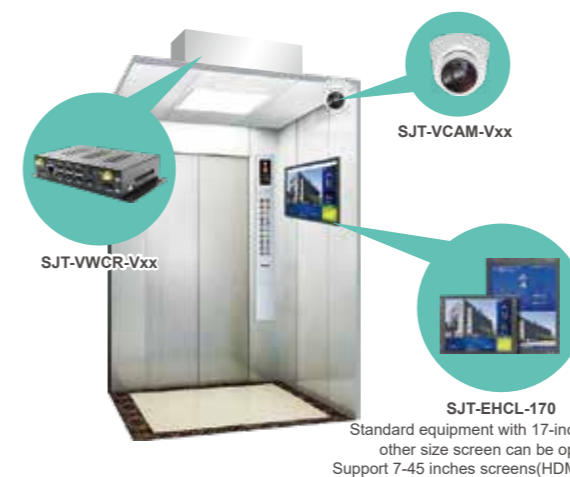

SJT-EHCL-170
Standard equipment with 17-inches screen, other size screen can be optional. Support 7-45 inches screens(HDMI Cable port).

- Video Monitoring
- Voice Announcement
- Video Recording
- Weather Forecast
- Playing Video and Audio
- Voice Soothing
- Rolling Subtitles
- Remote Video Intercom
- Show Noise and Vibration Curve
- Remote Upgrade

Elevator Cloud Facial Recognition Touch All-in-one Machine

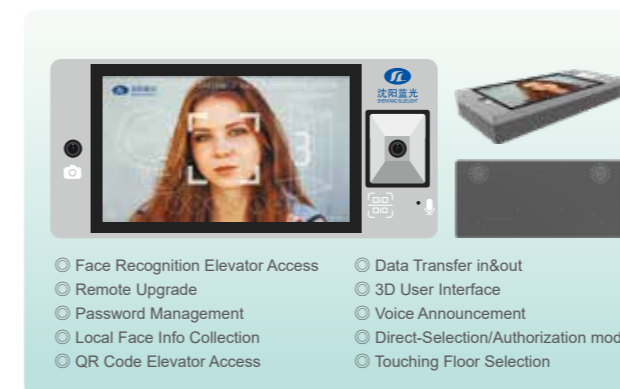

- Face Recognition Elevator Access
- Remote Upgrade
- Password Management
- Local Face Info Collection
- QR Code Elevator Access
- Data Transfer in&out
- 3D User Interface
- Voice Announcement
- Direct-Selection/Authorization mode
- Touching Floor Selection

Shenyang Bluelight 8-inch Facial Recognition Touch All-in-one Machine
Model: SJT-TFACE-080QR

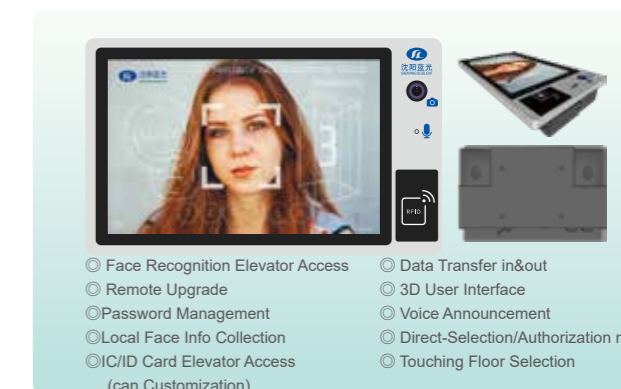

- Face Recognition Elevator Access
- Remote Upgrade
- Password Management
- Local Face Info Collection
- IC/ID Card Elevator Access (can Customization)
- Data Transfer in&out
- 3D User Interface
- Voice Announcement
- Direct-Selection/Authorization mode
- Touching Floor Selection

Shenyang Bluelight 8-inch Facial Recognition Touch All-in-one Machine
Model: SJT-TFACE-101

Touch-sensitive Landing Call Box

Features

- Capacitor touch key type landing-call UP and DOWN buttons, with built-in LED response light
- Car moving direction and current floor display
- Elevator locker. Special mode indication (Overload, Fire, Inspection, Stop).



SJT-CHT Series Touch-sensitive Landing Call Box

Input Voltage	24V(DC)
Temperature	-20~60°C
Waterproof	Prevent the effect from moisture, dew, spray and wet hand. Protect system safety and stability.
Oil Proof & Dust Proof	Oil and dust proof: effectively protect panel from greasy dirt and hall call box from getting in dust. Protect system safety and stability.
EMC	National Standard ESD, Group Impulse and EMI tested etc
Mounting Size	375 X 86 X 20mm

XS457 Landing Call Box

Features

- Size: 326mm X 90mm X 12.4mm
- Suitable with BL2000-HEH-N4.3 Display Board and above version, BL2000-HAH-N6.1 Display Board and above version
- Display type: Segment (vertical) display, dot-matrix (vertical) display
- Texture: Hairline finish, mirror finish;
- Features: 1. styling look; 2. Flat backing, easy installation.



Vibration & Noise Tester

Features

- Measure vibrations in X, Y, Z axis direction and the axial accelerations.
- Automatic compute elevator moving distance.
- Automatic compute maximum running noise.
- Automatic plot and display real-time elevator vibration curve, acceleration curve, velocity curve and displacement curve.
- Built-in Bluetooth wireless communication module.
- Elevator data can be uploaded online and store, manage on Cloud.
- Automatic calculate A95 values of elevator vibration speed and acceleration.



Intelligent Card Management System

Features

- Different IC card class level allows accessibility to different floors.
- Visitor recognize function.
- Support non-contact read/write, makes the IC card more reliable to use.
- Set working time and times to achieve whole building control or only selected floors control.
- Manage IC card issue, lost report, sign off and authorization.
- Inquire IC card issuance information, payment history and usage records.
- Compatible with door access control card. One card with multiply functions.



USBREADER



IC Card Management Controller BL2000-CIC-V4.1

Bluelight Elevator IC Card Control System (Separate Antenna)

Bluelight Elevator IC Card Control System (model: BL2000-CIC-V4.1 -TF)

Separates the signal receiving antenna plate from control circuit board, and connects them by a 1 meter radio frequency cable. For installation, only need to drill a hole on the car operation panel and fix the antenna by thread. So, there is no space limitation on the control board, it can put into any place as desire. This will save the car operation panel from brutally cut open and avoid further repair.

Features

- Anti-copy Function: Rolling code prevents from copying. Copy card is invalid.
- Report lost card/ disabled card: It register any specified IC cards which are lost or disabled.
- Cancel card lost or disabled stats: To recover any specified IC cards which have been previously registered as lost or disabled.
- Elevator access permission control: To configure owners access permission optionally.
- Time limit and count limit of usage control: It control the time of usage and number of usage times freely.
- Enable IC card control on random floor: To configure the floors accessibility with IC card randomly by activating each floor IC card function.
- Data management: To view information and records of distributed IC cards; to view payment information and payment record.
- Control data management: To read the information from IC Card controller such as lost or disabled IC cards, IC Card usages and to calibrate time and date.





Bluelight Remote Monitoring System

Features

- ◎ No debug required, device can be used immediately after powered.;
- ◎ Monitoring all information including real-timed data, statistical information, faults and event information.
- ◎ Connected with local platform. Our company's IOT products have the authority to connect with local platform.
- ◎ Fast recording, device ID paste on the shell. Users can read it directly or writing via APP scan.



Model	Features
SJT-WCR2-V2	Support 4G full network access(China Mobile, China Unicom, China Telecom) to connect with Bluelight Elevator Cloud Platform
SJT-TWCR-V2	Support 4G full network access(China Mobile, China Unicom, China Telecom) to connect with Bluelight Elevator Cloud Platform Voice Notification: device will have voice notification when Incoming Call, Outcoming Call, Call Ending and special status. One-button dialing: Dialing the saved phone number(Max 5 sets of phone number) in order after pressing the dial button 1 second. Special Status Notification: maintenance expiration reminder, ARD abnormality notification, SIM card abnormality notification, 4G signal weak notification. Privacy Guard: After opened No Auto Answering Function, need press the button manually to answer incoming call for privacy guarding. Calling Timeout: the longest calling time is 20mins(can set), auto hang up after time out for avoiding the calling fee if forget hanging up. Anti-harassment: Only allow the phone number those saved already can be calling in.
SJT-WCR2-WL1	Support 2.4Ghz WIFI network or wire network to connect with Bluelight Elevator Cloud Platform.

Weighting Device

Model: SJT-151/201

- ◎ Size: 90 X 60 X 35mm;
- ◎ Weight:200g;
- ◎ Cylinder Structure, light & small, easy installation.
- ◎ SJT-151: 485 communication, installed under car bottom, non-contact installation.
- ◎ SJT-201: CAN communication, installed at rope end or under car bottom, non-contact installation.
- ◎ Convert the deformation of car bottom or rope end info electrical signals, then send to control board as load value feedback.



Model: SJT-102

1. Features

- ◎ Size:86.4 X 34mm;
- ◎ Untouched magnetic induction working mode, no change of cabin structure or rope end.
- ◎ Highly sensible for stable and reliable result.
- ◎ Two channels for full load and overload outputs(OC output).

2. Functioning

- ◎ Refer to the deformation of car bottom or rope end to output full load and overload signals.

3. Application

- ◎ Car bottom with deformation(Car bottom install) or rope spring(rope end install)

Elevator Bluetooth Debugging Tool & Elevator Expert(IECS) APP

Elevator Bluetooth Debugging Tool

Bluelight self-developed a specific hardware for wireless communication between mobile phone and integrated cabinet by co-operate with Elevator Expert(IECS) App. This tool can adjust the elevator setting by mobile phone. Plug-in the debugging tool into integrated board, mobile phone can be communicate with the elevator board via Bluetooth communication.



Elevator Bluetooth Debugging Tool

- ◎ Elevator Expert(IECS) App function isn't that simple for elevator installation and adjustments, it could do more than that.
- ◎ Shenyang Bluelight injects the debugging experience of tens of thousands of elevators every year into the "Elevator Expert". With a mobile phone, one can achieve one-click detection of the holding force, traction rope slip, elevator high-speed and low-speed operation diagnosis, guide rail installation quality assessment, balance chain deviation detection, and non-gear traction machine balance coefficient, etc. It also includes the functions of software oscilloscope, software data recorder, and terminal logic signal analyzer, and can directly communicate with technical experts.
- ◎ The new integrated scene debugging function significantly reduces the operational difficulty for on-site installation and debugging personnel, making elevator debugging more convenient and user-friendly.